



Convention Date (Germany): Nov. 16, 1928.

Application Date (in United Kingdom): Nov. 14, 1929. No. 34,841 / 29.

Complete Accepted: Feb. 16, 1931.

COMPLETE SPECIFICATION.

Improvements in Coding Machines.

We, CHIFFRIERMASCHINEN AKTIEN-GESELLSCHAFT, of Steglitzerstrasse 2, Berlin, W. 35, Germany, a German Company, do hereby declare the nature of this invention and in what manner the same is to be performed, to be particularly described and ascertained in and by the following statement:—

Coding machines having coding drums are known, in which there is rigidly connected to the body of the coding drum a control member for advancing the coding drums. Such a control member may consist of a ring provided with a single notch for the engagement of a pawl or a tooth-gap for the engagement of a driving pinion.

It has also been proposed to provide on the bodies of the coding drums character rings which are rotatable and adjustable with respect to them, for expressing the coding key in another way than by characters arranged directly on the actual drum bodies. The forward feed of the separate coding drums was effected in each case in accordance with the position of the single notch or the single tooth-gap in the control member with respect to the body of the coding drum according to a definite system of connections as determined by the wire connections in the interior of the coding drums. The shiftability of the character ring is of only small advantage, as this shiftability did not find expression in the coded message and no fresh transpositions (variation in alphabetic correspondence) of those parts which are essential for the coding were effected.

In an arrangement of this kind it may occur that in spite of the character ring being turned, that is to say with a totally different code key designation, nothing will be changed as regards the position of these coding drums with respect to the other coding drums, thus offering an additional possibility of unauthorised decoding.

According to the invention the control member is connected to the rotatable and fixable character ring. This provides the advantage that, on the character ring being displaced with respect to the body of

the coding drum, not only is the key made more obscure, but the drive of the coding drum which happens to be the adjacent one is fundamentally changed. In a modified constructional form means are provided through a plurality of notches or tooth-gaps, the number of which is preferably a prime number, for bringing about a particularly frequent shifting of adjacent coding drums and thereby producing each time the character rings are displaced a particularly favourable setting of the controlling mechanism. It is of particular advantage for the various coding drums to have different numbers of points of application for the control member (notches, tooth-gaps or the like) prime numbers being again preferable for this purpose.

In another constructional form the control member is connected to the character ring so as to be releasable and in some cases interchangeable, thus further increasing the secrecy of the code.

The invention is illustrated by way of example in the accompanying drawings in which

Fig. 1 is a side elevation of a coding machine partly in section,

Fig. 2 an end view of a single part (coding drum),

Fig. 3 a view partly in cross-section and partly in side elevation of the said separate part.

Fig. 4 a plan view of a coding machine of a somewhat modified form to that shown in Fig. 1,

Fig. 5 is a partial end view of a separate part of the construction shown in Fig. 4 (coding drum),

Fig. 6 the same detail partly in section and partly in elevation,

Fig. 7 a rear view of Fig. 5, Fig. 8 a partial cross-section through a coding drum of somewhat different construction.

In Fig. 1 the reference 1 indicates the character transmitting members (keys) which bear the separate characters, for instance the letters of the alphabet. The parts 2 are character indicators, for instance incandescent electric lamps which, on a key 1 being depressed, light up and cause the characters in the coded or decoded message to appear on a transparent

55
60
65
70
75
80
85
90
95
100
105

disc 3 which is disposed above the incandescent lamps and which bears the same characters, for instance letters, as the keys. At 4 a plurality of coding drums lying one behind the other is indicated which are provided on both sides with electric contacts corresponding to the number of characters on the keys. The contacts on one side of the coding drums are connected to the contacts on the other side of the same coding drums by electric conductors which are arranged as irregularly as possible. The coding drums which are arranged one behind the other are connected together electrically by the contacts on their faces so that on a key being depressed the electric current must flow from a source of current (not shown) through all the drums along a zig-zag path, as it were, before reaching the character indicators 2 and causing the corresponding incandescent lamp to light up. The arrangement of such separate coding drums one behind the other is shown in Fig. 4. Such arrangements are already known, for instance through British Patent 163,357.

During the coding operation, that is to say on a key being depressed, the drums are in such coding machines turned with respect to one another with the object of continuously changing the coding key during coding. In Fig. 1 the part 5 is a lever which is rocked on one of the keys 1 being depressed so that it moves into the position indicated by 5'. At the end of this lever is a pawl 6 which is shown at 6' in the rocked position. This pawl is capable of engaging in a ratchet wheel 7 and, on a key being depressed, shifting one of the coding drums, for instance the coding drum 4, through the distance of one tooth in the direction of the arrow A. A stop member 8 is provided which on the pawl 6 being rocked allows the coding drum to advance only by exactly one forward step through the pawl striking with its edge 9 against the edges 10 of the stop member, thus preventing it from moving outwards and the edge 11 by striking against the flank 12 of one of the teeth preventing the coding drum from being further advanced through the mass of the drum being accelerated beyond the desired forward step.

The other coding drums are displaced either by a depression of the keys causing similar pawls to be put in motion, which engage in corresponding notches in the adjacent coding drums or by being driven by a coding drum through any suitable means, for instance pinions, which engage in toothed wheels on the adjacent coding drums and are themselves put in motion by a tooth-gap on the preceding

coding drum similar to those employed in the counting mechanism of calculating machines. Such a method of advancing single coding drums 14, 15, 16 from a coding drum 13 by means of pinions 17, 18, 19 is shown in Fig. 4, tooth-gaps 20, 21, 22 for driving these pinions being also indicated. For setting a definite coding key in such a coding device the characters, for instance the letters of the alphabet, are marked on the coding drum themselves or on rings mounted on the coding drums. These rings hereinafter referred to as character rings are capable of rotating and of being fixed with respect to the coding drums. Such character rings are shown by way of example in Fig. 4 at 23, 24, 25 and 26 and in Fig. 3 at 27.

For setting the coding key, that is to say for turning the coding drums, the drums must be arrested in order that the separated coding drums shall make contact with one another, so that the contacts on the drums will be in exact register and consequently the passage of the electric current will be secure under all circumstances. For this purpose detents 28 are provided with rollers 29 which engage in notches 30 on the notched wheels 31. These notched wheels are rigidly connected to the individual coding drums. Besides in Fig. 1, such detents are shown in Fig. 4 at 32, 33, 34, 35 with detent rollers 36, 37, 38, 39. In Fig. 4 these detents and detent rollers are shown in the position in which they are just out of engagement with the corresponding notched wheels 40, 41, 42, 43.

The forward feed of the individual coding drums during the coding operation is thus effected by a separate control member consisting either of a ring or disc provided with a notch and connected rigidly to the coding drum or of the tooth-gaps 20, 21, 22, already referred to, which were mounted either directly on the drums or on the rings 44, 45, 56. In this case the rings are also rigidly connected to the body of the coding drums.

According to the invention these control members are connected to the character rings which are capable of being rotated or fixed and are thus themselves capable of being set. This connection is established by such a control member in the form of a ring 47 (Figs. 2 and 3) being connected by screws 48 rigidly with the corresponding adjustable character ring 27. Another constructional form is shown in Figs. 5, 6 and 7, in which the control member consists of a ring 49 having three tooth-gaps 50 and forming a single piece with the adjustable character ring 51.

In another constructional form shown in

70

75

80

85

90

95

100

105

110

115

120

125

130

Fig. 8 an independent ring 52 is provided as the support for a tooth-gap; this ring is however normally pressed firmly by a nut 53 against an adjustable character ring 54, being thus rigidly connected to it. In this last constructional form the ring 52 with its tooth-gap is also adjustable with respect to the character ring 54 and can be removed after the removal of the nut 53 so that the character ring 54 may be combined with another ring 52 having tooth-gaps of a different kind, for instance a plurality of such gaps.

By this arrangement the great advantage for coding is obtained that a displacement of the character ring will not only set a different coding key but will also change the way in which the other coding drums are advanced and thereby change the substitute alphabet. This increases the safety of the coded message against being decoded by an unauthorised person.

While in the hitherto known coding devices of such a type having coding drums and a control member for advancing the coding drums by means of a control part, for instance a pawl or a pinion and character rings with a control member, only a single point of application for the control part, for instance a single ratchet notch or only one tooth gap acting on the connecting pinion is provided, according to the invention the control member is provided with a plurality of such points of application.

In Figs. 1 and 2 this is indicated by three points of application (ratchet notches 55).

In Fig. 7 this is indicated by three tooth-gaps 50 on the ring 49 which is integral with its corresponding character ring 51.

The number of points of application is preferably a prime number, this number in the example shown being the prime number 3.

A particular advantage is obtained if the number of points of application on the control member is different in each individual coding drum and if the numbers are as far as possible not divisible by a common divisor.

The result of such an arrangement is that during the coding operation by displacing the adjustable character ring a different forward feed, namely a particularly frequent forward feed of the coding drums is effected and consequently a frequent change of the substitute alphabet, while by using a prime number for the number of points of application

a repetition of the same substitute alphabet will be prevented, which would result in a shortening of the coding period.

The prime numbers are so selected that none of these prime numbers is divisible into the number of characters on the character rings, for instance the number of 26 letters.

In Figs. 5 to 8 the part 60 is the body of the coding drum, 61 are the contacts on one side 62 the contacts on the other side, 63 the electric conductors, 64 the notched wheel, 65 the ring of teeth which meshes with a corresponding pinion by which it is driven, as shown in Fig. 4.

Having now particularly described and ascertained the nature of our said invention and in what manner the same is to be performed, we declare that what we claim is:—

1. A coding device having coding drums or wheels and a control member for advancing the coding drums by means of a feed member for instance a pawl or a pinion and having character rings which are capable of rotating and of being fixed with respect to the coding drum bodies, characterised by the feature that the control member is connected to the rotatable and fixable character rings and is thereby itself rendered capable of being adjusted and fixed.

2. A coding device as claimed in claim 1, characterised by the feature that the control member has a plurality of points of engagement for the feed member, for instance a plurality of notches for the engagement of a pawl or of tooth-gaps for the engagement of driving pinions.

3. A coding device as claimed in claims 1 and 2, characterised by the feature that the number of points of engagement is a prime number.

4. A coding device as claimed in claim 2 or 3, characterised by the feature that the number of points of engagement on the separate coding drums is different and that the numbers are as far as possible not divisible by a common number.

5. A coding device as claimed in claims 1 and 2, characterised by the feature that the control member is connected to the character ring so as to be releasable and if required exchangeable and is thereby rendered capable of being set with the points of engagement for the feed member to any desired characters on the character ring.

Dated this 13th day of November, 1929.
MARKS & CLERK.

[This Drawing is a full-size reproduction of the Original.]

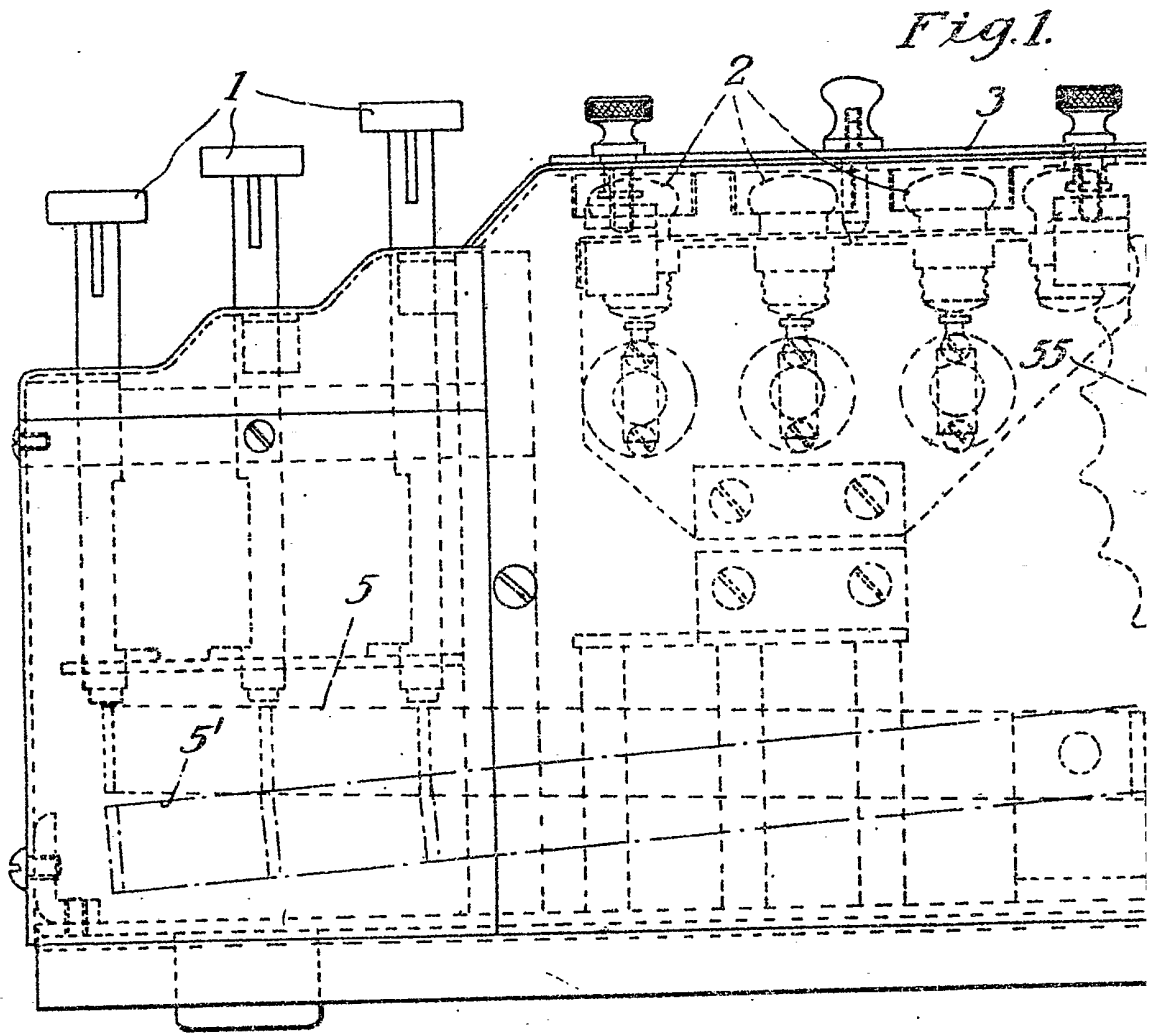
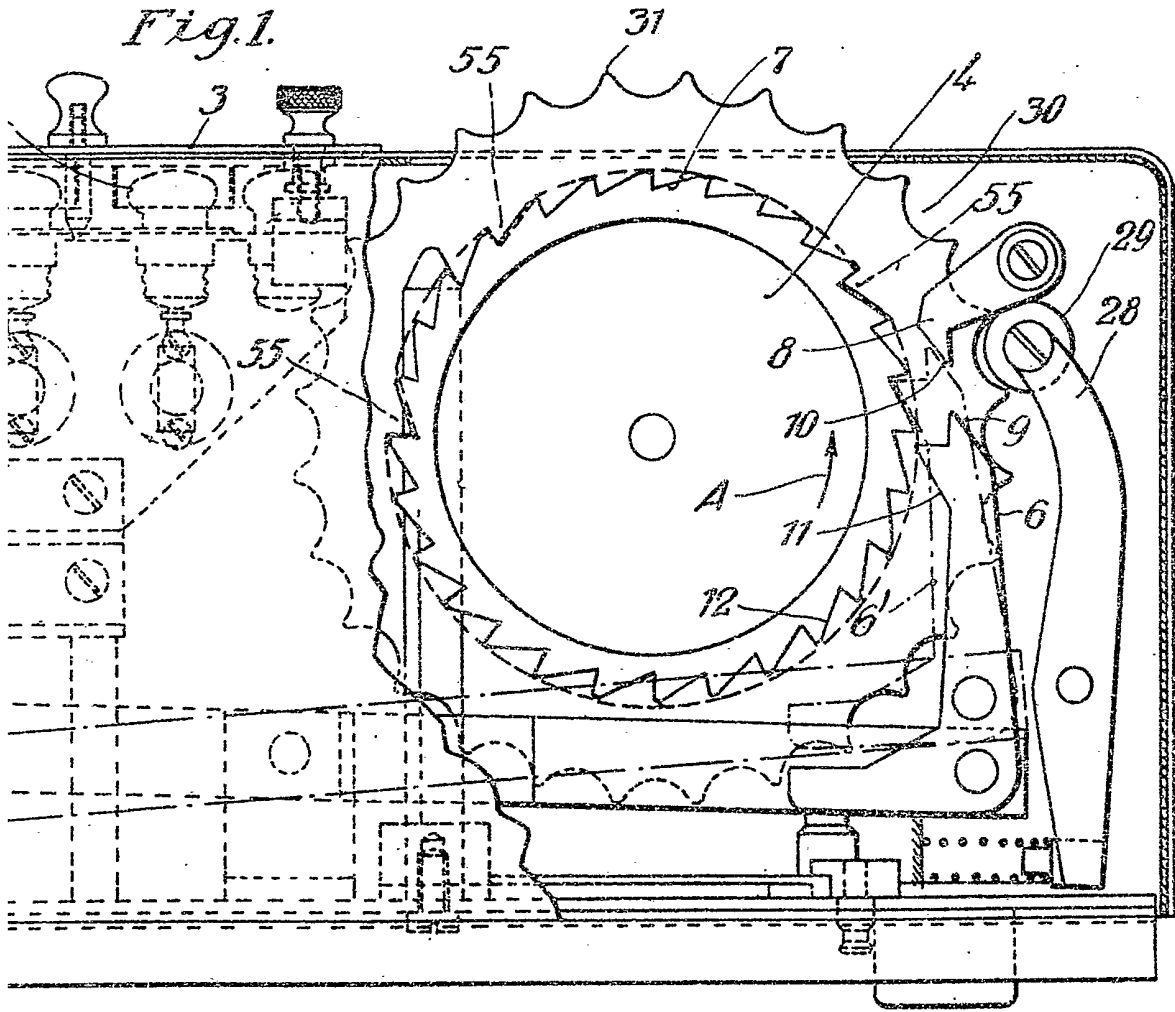
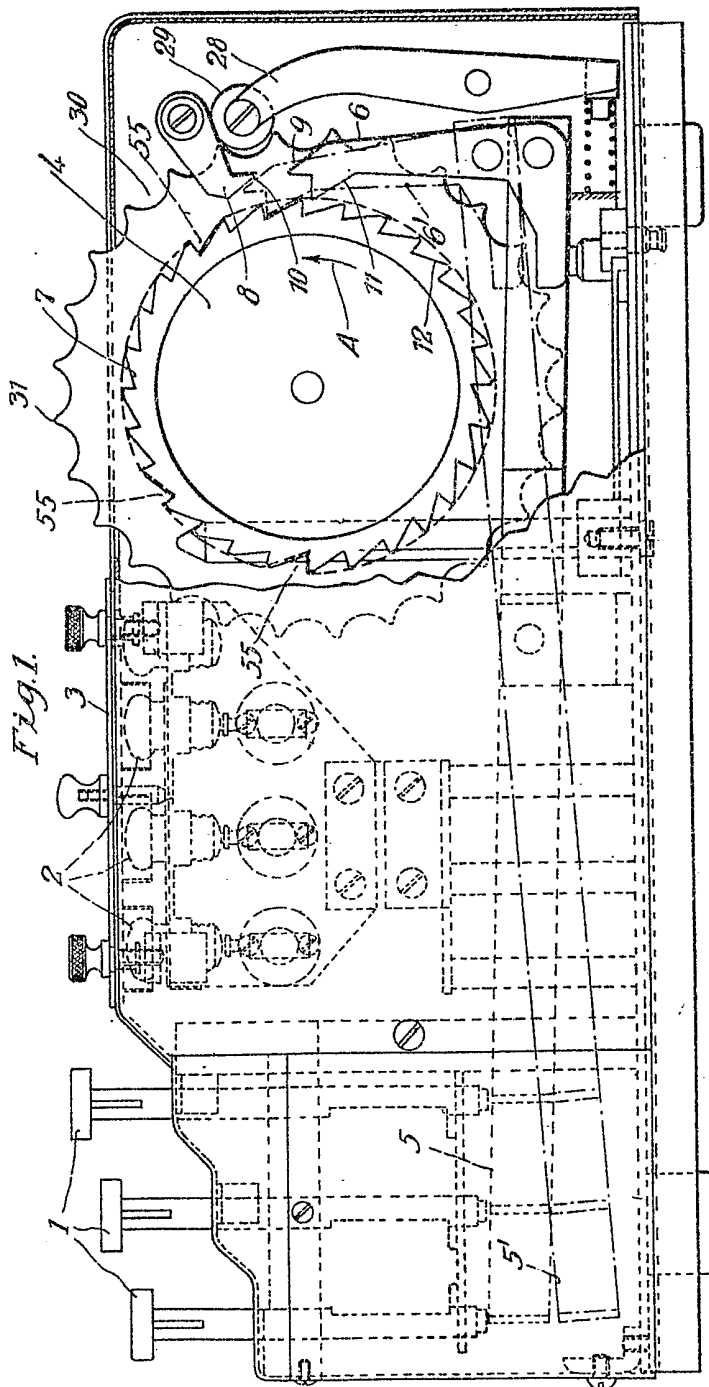

Fig. 1.





[This Drawing is a full-size reproduction of the Original]

Fig. 3.

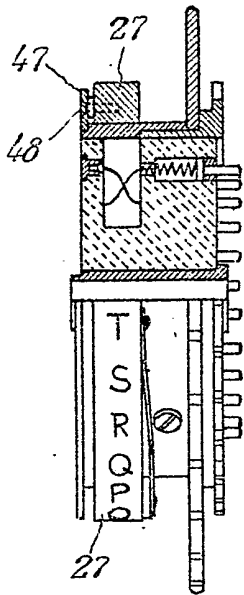

Fig. 2.

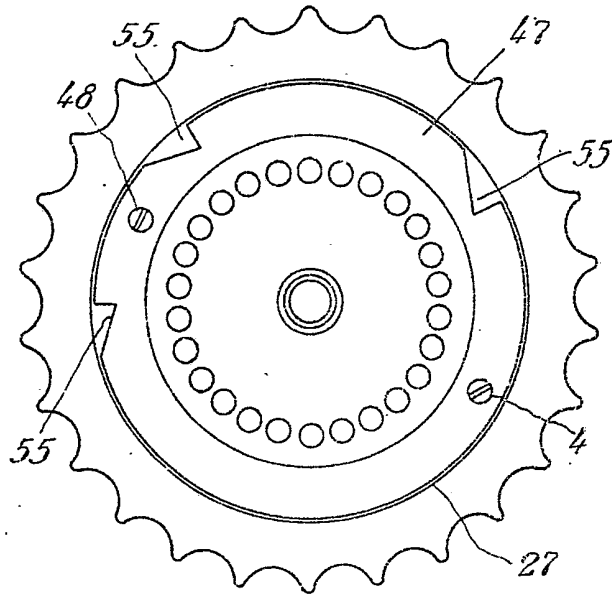
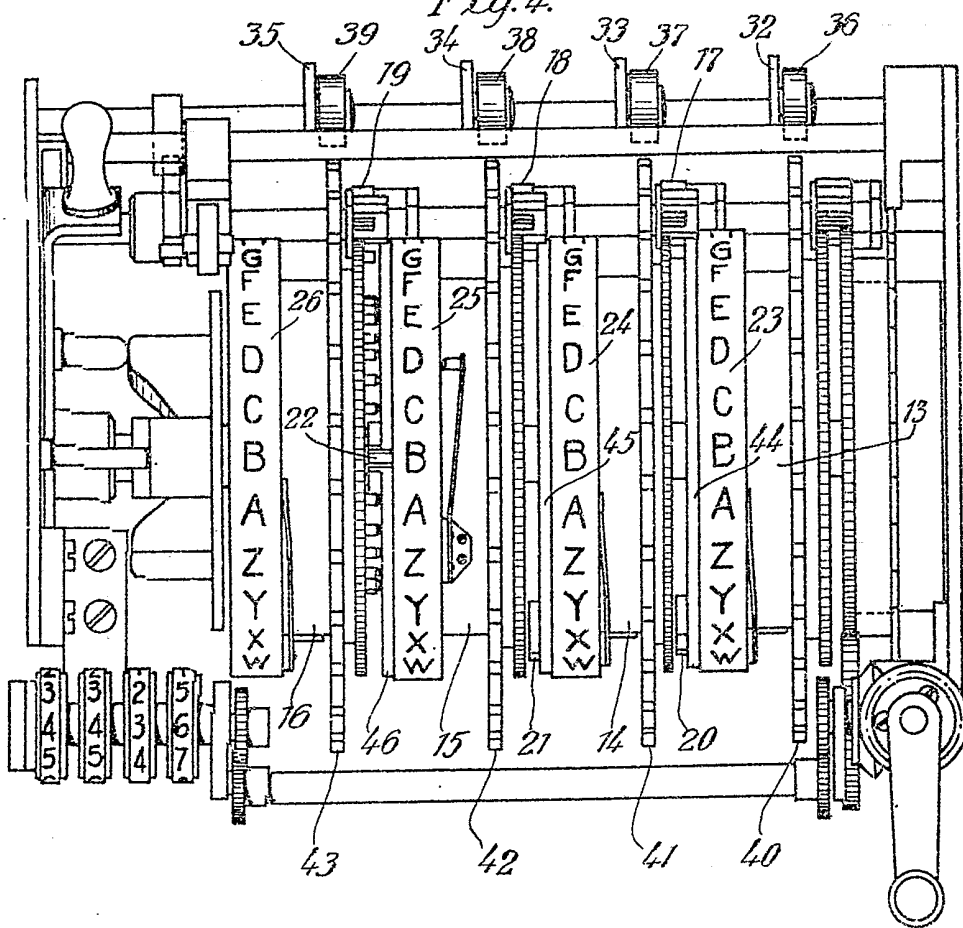

Fig. 4.



[This Drawing is a reproduction of the Original on a reduced scale.]

7
55
4
7

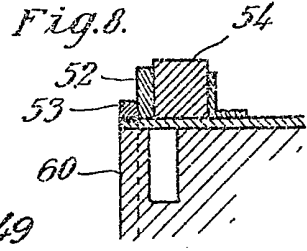
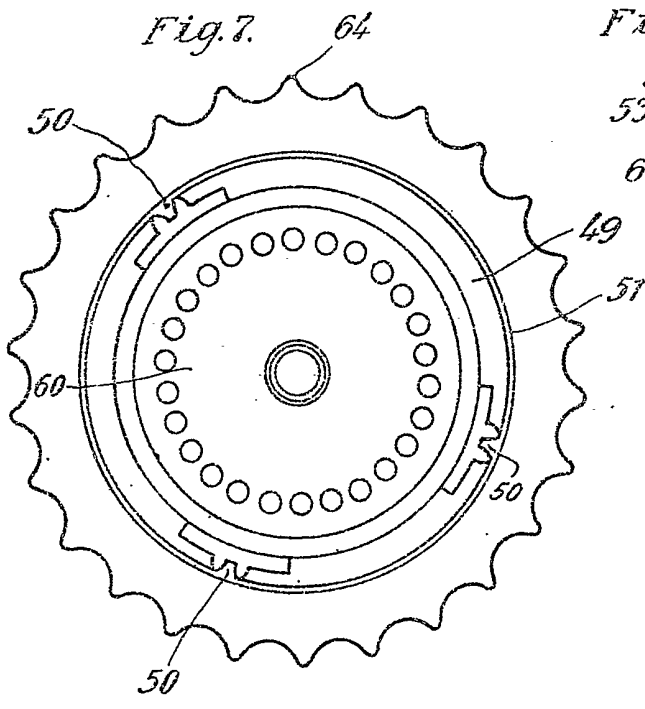
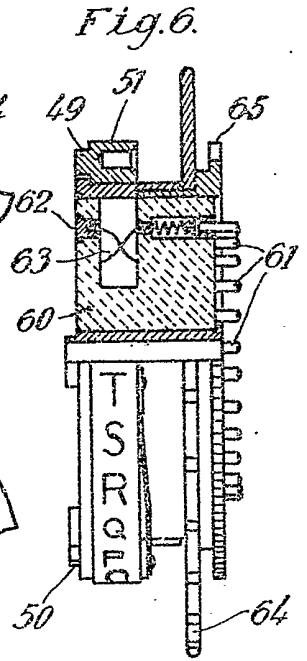
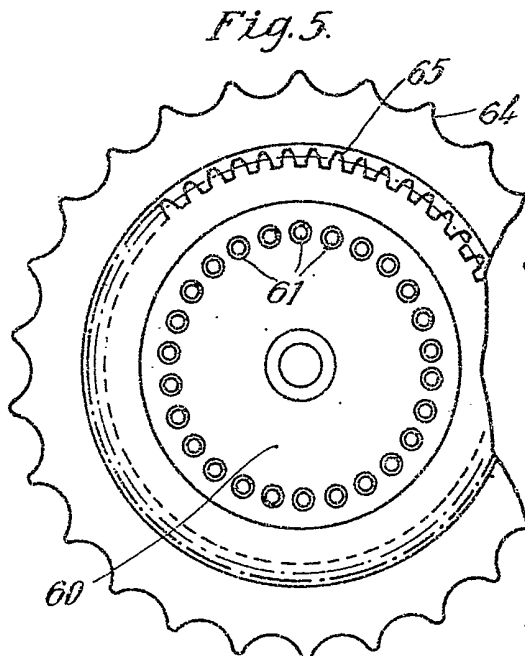
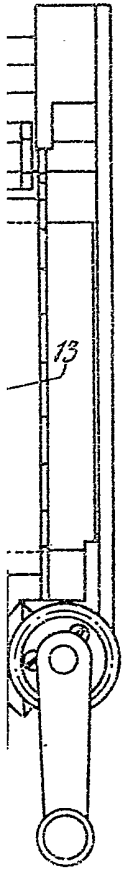

Fig. 3.

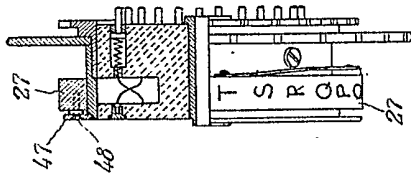

Fig. 2.

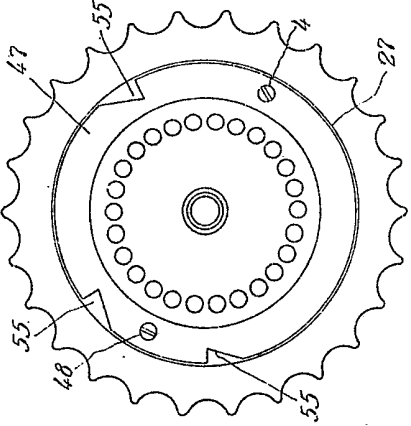

Fig. 5.

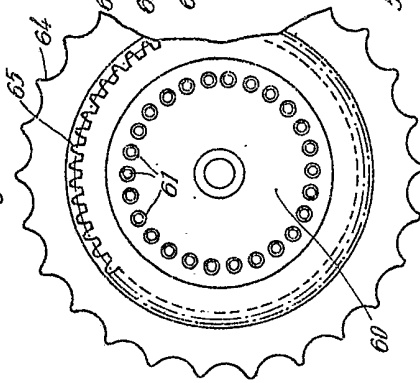

Fig. 6.

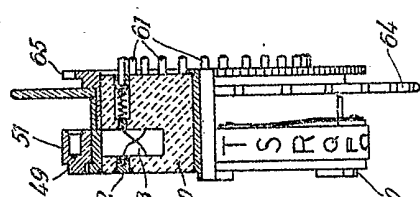

Fig. 7.

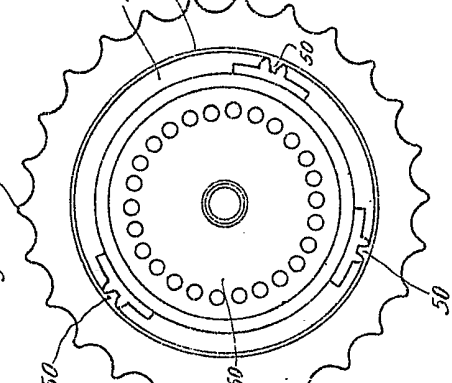

Fig. 8.

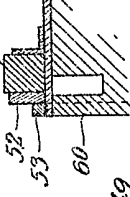
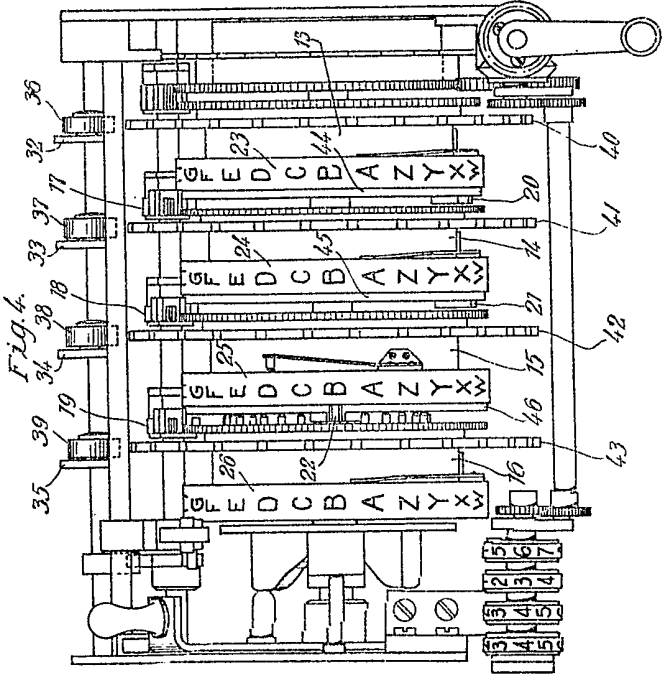

Fig. 4.



[This Drawing is a reproduction of the Original on a reduced scale]